



Al Andalus
Electrical solutions



Oviedo 1

ALHB101

- Applications

Oviedo 1 fixtures provide powerful, efficient, and focused lighting, designed for large spaces with high ceilings in industrial and commercial settings. Applications include:

- Warehouses.
- Manufacturing facilities.
- Gymnasiums.
- Retail stores.
- Exhibition halls.
- Indoor farming.
- Airplane hangars.
- Parking garages.
- Cold storage facilities.

- Features

LED:

- SMD [Lumileds]

DRIVER:

- Constant current driver.
- IP[65].

HOUSING:

- [The body is made of aluminum die cast.]
- IK[10].
- Finishing color[Black]

- Dimensions

Model	ALHB101
∅	301 mm
H	222 mm

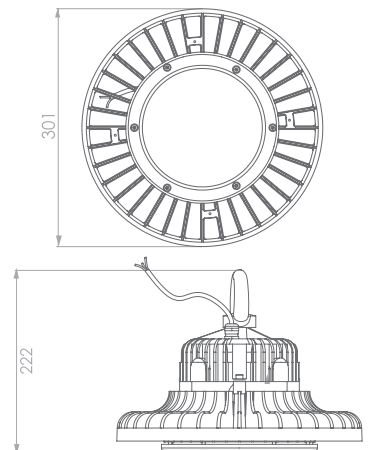



Al Andalus
Electrical solutions

Oviedo1

ALHB101

- Tech.Specification

Model	ALHB101-100	ALHB101-150	ALHB101-200
Power	100 W	150 W	200 W
Power factor	> 0.95		
Luminous Efficacy	150 lm/W		
Luminous flux	15000 lm	22500 lm	30000 lm
CCT	5700 K - 6000 K - 6500 K		
Baem Angle	120°		
CRI (Ra)	>70		
IP	65		
Weight	4.4 KG		